

# RELAY DRIVER BOARDS

# DC-37 DVR

## DC-37 RELAY DRIVER BOARD FOR 4813/2313/8013S

### Description

The DC-37 Relay Driver Board expands the 4813's, 2313's or 8013's output drive capability by adding 64 heavy-duty solenoid drivers to its output signals. The DC-37 Relay Driver is designed so that the 64 of the output lines have relay drivers and 64 lines are preserved as TTL I/O lines. The relay driver board's signals are organized in four groups of 16 relay drivers and 16 I/O lines. Each group is brought out on a 37-pin, DC shell female connectors. Applications include building relay matrixes, switching relays, driving high power displays or sinking any high power load.

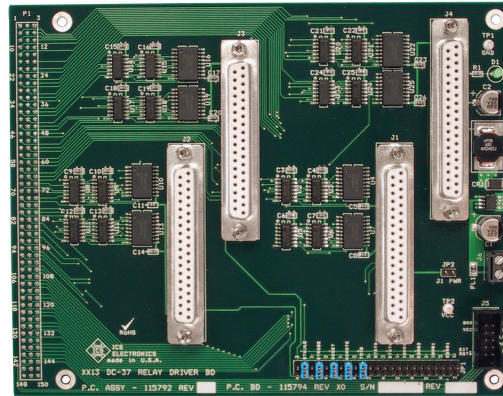

DC-37 Relay Driver Board

- Provides up to 64 drivers for driving external relays or other heavy loads. *Eliminates the need for external drivers and logic circuits.*
- Provides 64 heavy-duty TTL I/O lines *Input TTL/CMOS data, sense contact closures or use as TTL outputs*
- An internal power supply powers the mating 4813, 2313 or 8013 Interface Board. *Eliminates a separate 5 volt power supply.*
- Relay drivers and I/O lines provided on four DC shell female connectors. *Commonly available connector makes for easy connection.*
- Mates with standard 2313, 4813, and 8013 Boards. *Drive relays and digital signals from the GPIB bus, a Serial source or from the company network.*

RoHS Compliant

### Compact Assembly

The DC-37 Relay Driver Board fits on top of a 4813, 2313 or 8013 Interface Board to make a compact assembly that is only 1.38 inches high. The DC-37 Relay Driver Board is the same size as the xx13 board it mounts on. The assembly is held together with four standoffs that can be used to mount the assembly in the chassis or against a mounting surface. The DC connectors on top of the DC-37 Relay Driver Board are mounted vertically and are easily accessible for plugging in the mating connectors,

The DC-37 Relay Driver contains a small switching regulator that supplies 5 volt power to the 4813, 2313 or 8013 Interface Board, eliminating the need for a separate 5 volt power supply. The DC-37 Relay Driver accepts 9 to 32 V DC power and can use the same power supply that powers the external relays.

### High Current Relay Drivers

The DC-37 Relay Driver Board is equipped with 64 open-collector darlington type drivers that can sink up to 500 mA to operate relays, solenoids or other heavy loads. The drivers can handle voltages up to 48 volts and include clamp diodes for driving inductive loads. The DC-37 Relay Driver's driver circuits have been designed to be glitch free so as to not pulse the external relays at power turn-on or turn-off time.

### I/O Lines

The 64 lines with out relay drivers are heavy-duty TTL I/O lines that can be used as inputs or outputs. As outputs they source up to 24 mA or sink up to 48 mA. As inputs, they can sense contact closures or input TTL or CMOS signal levels.

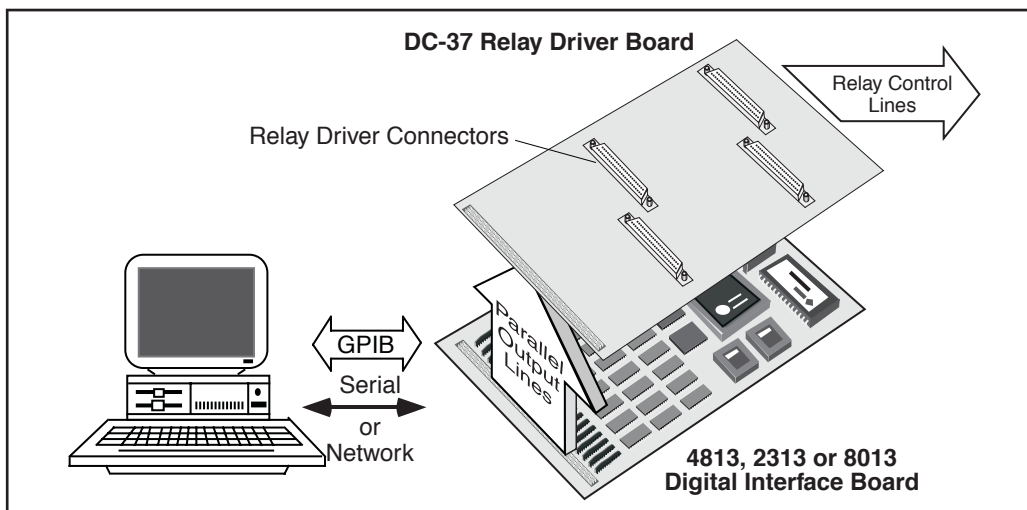

Adds Relay Drivers to a 2313, 4813 or 8013 Board



7034 Commerce Circle  
Pleasanton, CA 94588  
Phone: 925.416.1000  
Fax: 925.416.0105  
Web: [www.icselect.com](http://www.icselect.com)

## DC-37 DVR: Description

### Connector Organization

Each DC-37 Connector has 16 Relay Driver outputs, 16 TTL I/O lines, an unassigned signal line plus a relay power line and two relay return lines. The relay power line is used for the anti-backlash diodes in the relay drivers and does not draw any power.

Each connector also has an unassigned signal that goes to a signal jumper strip. The jumper strip is arranged so that any xx13 control, strobe or handshake signal line can be routed out to any connector by inserting shorting pins between the two signals. By opening the Stable-Relay Enable signal, the user can externally disable all of the relay drivers.

Table 1 on the right shows the signal pin assignments for Connector #1. Bytes 1 and 2 are the TTL I/O lines, bytes 3 and 4 are the relay driver outputs. The remaining connectors have similar signal-pin assignments.

### SCPI Commands control the Relays

The signals on each DC-37 Connector correspond to four I/O bytes on the xx13 board and can be controlled with the xx13 board's SCPI or Short Form commands. Table 2 lists the SCPI commands used to control the I/O lines in the 4813, 2313 or in the 8013. All three interface cards respond to the SCPI syntax or to their corresponding Short Form commands. The command formats can be used interchangeably.

The bit commands use the SCPI ROUTe branch. ROUTe:CLOSE enables a single driver which closes a relay or operates a solenoid. ROUTe:OPEN disables the relay driver which opens the relay. Latching relays can be switched by pulsing the relay driver on for a short period of time. This can be done by inserting a brief delay between the close and open commands to achieve the desired pulse width. The ROUTe:RESET command disables all of the drivers controlled by that byte.

The SOURce branch lets you control all 8 lines in a byte with one command. Use the SCPI SOURce:DATA:PORTn command or the short form BOn command to control the I/O lines.

The SENSE branch lets you read the state of the I/O lines that are bypassing the relay drivers and are connected directly to the headers. The SENSE:DATA:PORTn? query or the BIn? query reads back all of the lines in a specific byte. SENSE:BIT? n or READ? n reads the status of a specific bit.

### 4813 Relay Driver Assembly

Figure 2 shows how a DC-37 Relay Driver Board mounts on any standard 4813, 2313 or 8013 Board. The DC-37 Relay Driver Board is positioned over J1 on the xx13 Board and pressed into place. A pair of 0.750 high female-to-male standoffs holds the front portion of the two boards together.

**Figure 2 DC-37 DVR Board mounted on top of a 4813/2313 or 8013 Digital Interface Board.**

**TABLE 1 DC-37 SIGNAL-PIN ASSIGNMENTS**

Signal	Byte	Pin	Signal	Byte	Pin
CH 4	Byte 1 Bit 7	2	CH 20	Byte 3 Bit 7	11
CH 3	Byte 1 Bit 6	21	CH 19	Byte 3 Bit 6	30
CH 2	Byte 1 Bit 5	3	CH 18	Byte 3 Bit 5	12
CH 1	Byte 1 Bit 4	22	CH 17	Byte 3 Bit 4	31
CH 8	Byte 1 Bit 3	4	CH 24	Byte 3 Bit 3	13
CH 7	Byte 1 Bit 2	23	CH 23	Byte 3 Bit 2	32
CH 6	Byte 1 Bit 1	5	CH 22	Byte 3 Bit 1	14
CH 5	Byte 1 Bit 0	24	CH 21	Byte 3 Bit 0	33
CH 12	Byte 2 Bit 7	6	CH 28	Byte 4-bit 7	15
CH 11	Byte 2 Bit 6	25	CH 27	Byte 4-bit 6	34
CH 10	Byte 2 Bit 5	7	CH 26	Byte 4-bit 5	16
CH 9	Byte 2 Bit 4	26	CH 25	Byte 4-bit 4	35
CH 16	Byte 2 Bit 3	8	CH 32	Byte 4-bit 3	17
CH 15	Byte 2 Bit 2	27	CH 31	Byte 4-bit 2	36
CH 14	Byte 2 Bit 1	9	CH 30	Byte 4-bit 1	18
CH 13	Byte 2 Bit 0	28	CH 29	Byte 4-bit 0	37
			V1+	Relay +V	1
			Sig#1	User signal	20
			Vret	Relay Return	10,29
			Vret	Power Gnd	19

**TABLE 2 PARTIAL 4813 SCPI COMMAND TREE**

SCPI Commands		Short Form Cmds
FORmat		
:TALK	<ASCii   Hex   HEXL   Table>	
:TRANslation	<16 char string>	V
:LISTen	<ASCii   Hex   HEXL   4833>	
ROUTe	<b>Bit Commands</b>	
:CLOSE	byte, bit	CLOSE
:OPEN	byte, bit	OPEN
:RESET	byte	BRESET
SENSE	<b>Input Data</b>	
[:DIGital]		
:DATA		
[:VALue]?		PI?
:PORT?	number or <channel list>	BI?
:PORTn?		BIn?
:POLarity?		IPn
:RESet:EDR		ER
:BIT?	0-1	READ?
:BYTe?	0-255	BREAD?
[SOURce]	<b>Output Data</b>	
[:DIGital]		
:DATA		
[:VALue]	0-255	PO
:PORTn	0-255	BOn
:POLarity	0-255	OPn
:STRobe		SP

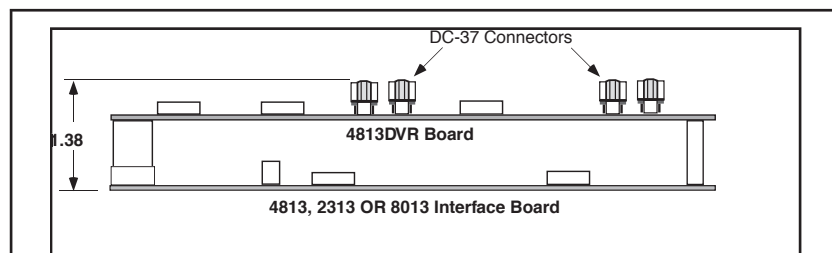

## DC-37 DVR: Specifications

### xx13 Interface

DC-37 DVR supplies a female 150-pin connector for mounting on top of a standard 4813, 2313 or 8013 board. Digital IO, LED drive and Handshake signals are brought up to the DC-37 DVR Board. 4813/2313/8013 power is supplied by a switching power supply on the DC-37 DVR board.

Supplied Power to 4813/2313/8013 board  
Voltage +5 ± 0.2 Vdc  
Current 500 mA max

### Digital Connections

The following lines are used by the DC-37 DVR Board:

128 Digital I/O lines  
Stable Signal  
External Reset Input

### LED Drive Signals

The lower board LED drive signals and Vcc are available on a 10-pin header to drive remote LEDs. The LED Drive Signals are low going. Limit LED current to 15 mA per LED.

### Miscellaneous Signals

The following lower board signals are brought to a jumper pin header and may be jumpered to the unused signal line on each 37-pin DC connector.

EDR#1 and EDR#2 inputs,  
Inhibit #1 and #2 outputs,  
Status A and Status B inputs,  
Data Strobe, Trigger, and Remote outputs,  
Reset and Stable outputs.

### Driver Characteristics

High power outputs for driving relays or other loads. Output lines controlled by 4813 Source commands with polarity set to high true.

Number :	64 Lines
Driver Form	Open collector with clamping diode.
Current	500 mA max per line 2.5 A total for all 8 lines in a byte.
Vout low	1.1 volts at 100 mA 1.3 volts at 200 mA 1.6 volts at 350 mA
V max high	48 Vdc

### Input Signal Characteristics

TTL inputs with pullups for CMOS signals and contact closures.

Number :	64
High	> 2.4 Vdc or open
Low	< 0.5 Vdc at 200 $\mu$ A
Pullup resistor	33 kohms to +5 Vdc on 4813 board.

### External Reset Input

TTL input signal that resets the 4813 board when pulled to ground. Pullup provided by the 4813 board.

### External Power Input

Use either the two-screw terminal block or Vin on Header #1

### Physical

Size, L x W x H  
177.8 x 139.7 x 14.3 mm  
(7.0 x 5.5 x 0.562 inches)

Assembled dimensions with 4813/2313/8013  
177.8 x 114.3 x 35.1 mm  
(7.0x 4.5 x 1.38 inches)

Weight 0.38 lbs (0.17 kg)

#### Connectors and Headers

4813 150-pin, 3 row female connector.  
Relays DC-37S (female) connector with 4-40 lock studs.

#### Temperature

Operation -10° C to +70° C  
Storage -20° C to +85° C

#### Humidity

0-90% RH without condensation

#### Power

+7 to + 32 Vdc @ 4 VA (typical)

### Included Accessories

Instruction Sheet  
4 0.75 inch 4-40 standoffs and hardware.  
Shorting jumpers

### Available Accessories

902047 DC-37P Male Connector  
902105 DC Hood

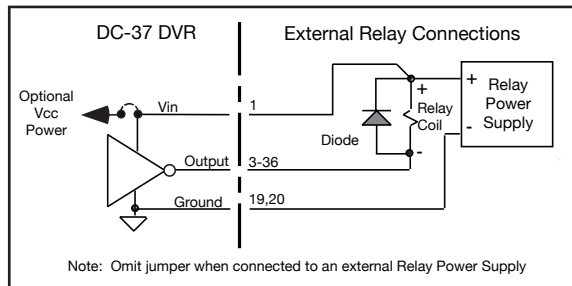

Figure 3 Typical Relay Driver Connections

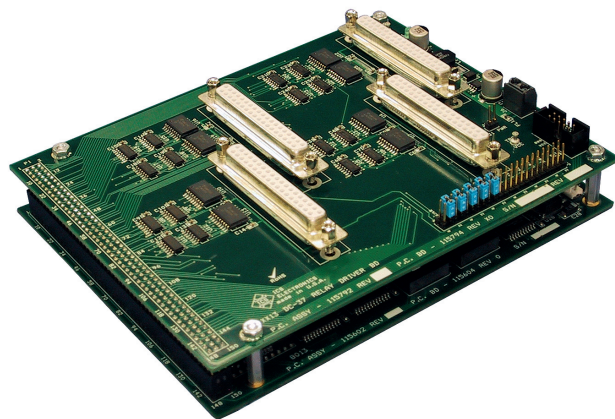

Figure 4 DC-37 DVR Board mounted on an 8013 Board

## ORDERING INFORMATION

DC-37 DVR Relay Driver Board for standard 4813/2313/8013 boards

Part Number

115790